



Drawing Triangles (Part 1)

Goals

- Draw triangles with two given angle measures and one side length, and describe (orally) how many different triangles could be drawn with the given conditions.
- Use drawings to justify (in writing) whether two given angle measures and one side length determine one unique triangle.

Learning Targets

- Given two angle measures and one side length, I can draw different triangles with these measurements or show that these measurements determine one unique triangle or no triangle.

Lesson Narrative

In this lesson, students build on their observations of triangles with shared angle measures and side lengths, by drawing their own triangles with specified measures: a given angle, two given angles, and two given angles and a given side length.

The purpose of the lesson is to help students see the structure of certain triangles—namely that sometimes the given conditions allow only one possible triangle, sometimes more than one, and sometimes none (MP7). Students also gain experience using various tools to draw triangles with given conditions.

Note that, in grade 7, students are not expected to know that the angle measures within a triangle have a sum of 180 degrees, although it is fine for them to use that information if they know it.

Standards

Addressing 7.G.A, 7.G.A.2

Instructional Routines

- MLR8: Discussion Supports
- Which Three Go Together?

Required Materials

Materials to Gather

- Geometry toolkits: Activity 2, Activity 3

Required Preparation

Activity 3:

For the digital version of the activity, acquire devices that can run the applet.

Student Facing Learning Goals

-  Let's see how many different triangles we can draw with certain measurements.



9.1

Which Three Go Together: Triangles

5 min

Warm-up

Activity Narrative

This *Warm-up* prompts students to compare four images. It gives students a reason to use language precisely (MP6). It gives the teacher an opportunity to hear how students use terminology and talk about characteristics of the items in comparison to one another.

Standards

Addressing 7.G.A

Instructional Routines

- Which Three Go Together?

Launch

Arrange students in groups of 2–4. Display the images for all to see. Give students 1 minute of quiet think time and ask them to indicate when they have noticed three images that go together and can explain why. Next, tell students to share their response with their group and then together to find as many sets of three as they can.

Student Task Statement

Which three go together? Why do they go together?

A

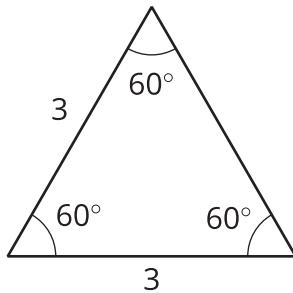

B

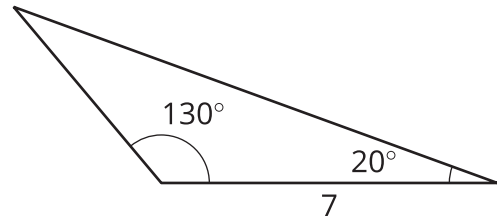

C

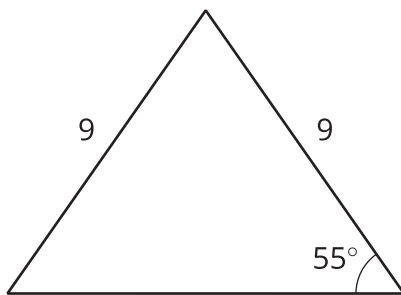

D

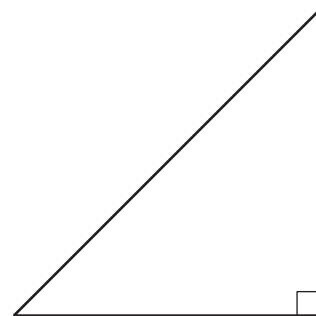

Student Response

Sample responses:

A, B, and C go together because:



- They do not have a right angle.
- They have labeled side lengths.

A, B, and D go together because:

- The angle measurements end in 0.

A, C, and D go together because:

- They do not have an obtuse angle.
- They label 1 or 3 angles.

B, C, and D go together because:

- Not all 3 angles are equal.
- Not all 3 sides are equal.

Activity Synthesis

Invite each group to share one reason why a particular set of three go together. Record and display the responses for all to see. After each response, ask the class if they agree or disagree. Since there is no single correct answer to the question of which three go together, attend to students' explanations and ensure that the reasons given are correct.

During the discussion, prompt students to explain the meaning of any terminology they use, such as "right angle," "acute angle," and "obtuse angle" and to clarify their reasoning as needed. Consider asking:

- "How do you know . . . ?"
- "What do you mean by . . . ?"
- "Can you say that in another way?"

9.2

Does Your Triangle Match Theirs?

 15 min

Activity Narrative

In this activity, students continue creating a triangle from given conditions and seeing if it will match a given triangle. This activity transitions from students just noticing things about triangles already drawn to students drawing triangles themselves to test whether conditions result in unique triangles.

As students work on the task, monitor for students who draw triangles that differ from those of their classmates.



Standards

Addressing 7.G.A.2



Instructional Routines

- MLR8: Discussion Supports

Launch

Arrange students in groups of 2. Give students 3–5 minutes of quiet work time, followed by time to check with their partner. Discuss whether any of the triangles they drew are identical copies. Follow with a whole-class discussion.



Provide access to geometry toolkits that include a ruler marked with centimeters and a protractor.

Student Task Statement

Three students have each drawn a triangle. For each description:

- Draw a triangle with the given measurements.
 - Measure and label the other side lengths and angle measures in your triangle.
 - Decide whether the triangle you drew must be an identical copy of the triangle that the student drew. Explain your reasoning.
1. Jada's triangle has one angle measuring 75° .
 2. Andre's triangle has one angle measuring 75° and one angle measuring 45° .
 3. Lin's triangle has one angle measuring 75° , one angle measuring 45° , and one side measuring 5 cm.

Student Response

Sample response:

Jada's Triangle

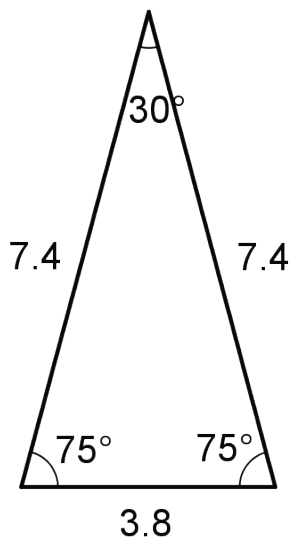

Andre's Triangle

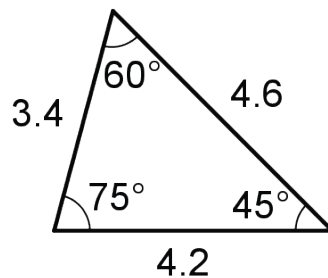

Lin's Triangle

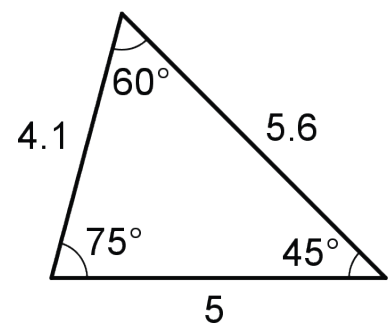

None of the triangles are guaranteed to be identical copies.

- The description of Jada's triangle is very vague. You can choose lots of other angles and side lengths.
- The description of Andre's triangle makes it so you can't choose the third angle measure (so all the drawings will be scaled copies), but you can still choose different sizes for the side lengths.
- The description of Lin's triangle might seem unique at first glance, but actually you could make any of the three sides be the 5-cm length, so you can still draw more than 1 triangle given these conditions.

Building on Student Thinking

Students may have trouble recognizing that Lin's triangle could have the pieces described in different orders. They are likely to immediately think of the side being between the two angles and not visualize other arrangements. Remind students of the task from the previous day and some of the triangles they saw there.

Activity Synthesis

Select previously identified students to share their triangles.

To highlight the fact that there could be different triangles drawn, ask:

- “Did anybody draw a triangle that was identical to one drawn by their partner?”
- “Do we know enough about Jada’s triangle to draw an identical copy of it? Andre’s triangle? Lin’s triangle?” (no)

If not mentioned by students, explain that it could be possible that we all drew identical copies for Lin’s triangle (because it is most straightforward to draw the 5-cm side in between the 75° and 45° angles). However, that does not mean that we were given enough information about Lin’s triangle to draw an identical copy of it. The problem did not say that we had to put the 5-cm side between those two angles.

Display the image of Lin’s triangle for all to see. Invite students to confirm that it matches the description of Lin’s triangle. Ask whether any student drew an identical copy of Lin’s triangle.

Jada’s Triangle

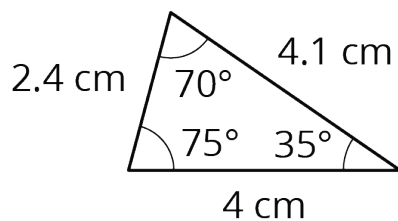

Andre’s Triangle

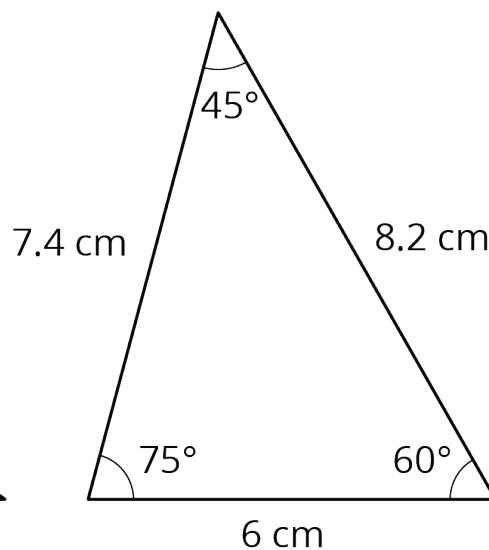

Lin’s Triangle

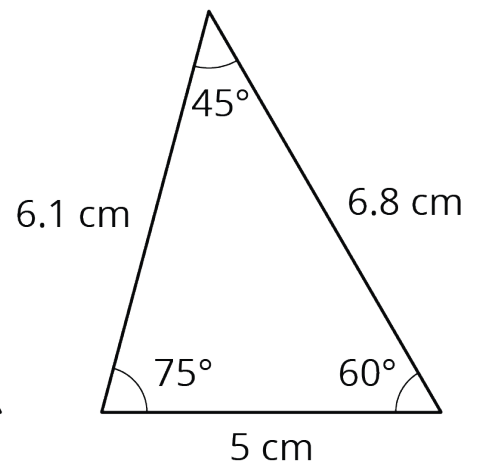

Introduce the word “unique.” Explain to students that in all three cases, the information given is not enough to determine a unique triangle, not even for Lin’s triangle, because there is more than 1 way we can draw a triangle with those given conditions. Ask students, “What information would Lin have to give us to make the triangle unique (so we knew our drawing would be an identical copy of her triangle)?”

Before moving on to the next activity, it would be helpful to model how Lin drew her triangle:

1. Draw the 5 cm segment.
2. Draw the 75° angle on one end of the segment, with a very long ray.
3. Place a protractor along the ray.
4. Line up a ruler at the 45° mark on the protractor.
5. Keeping the ruler and protractor together, slide them along the ray until the edge of the ruler intersects with the other end of the 5 cm segment.
6. Keeping the ruler in place on the paper, remove the protractor from underneath it.
7. Draw a line along the ruler from the ray to the segment.

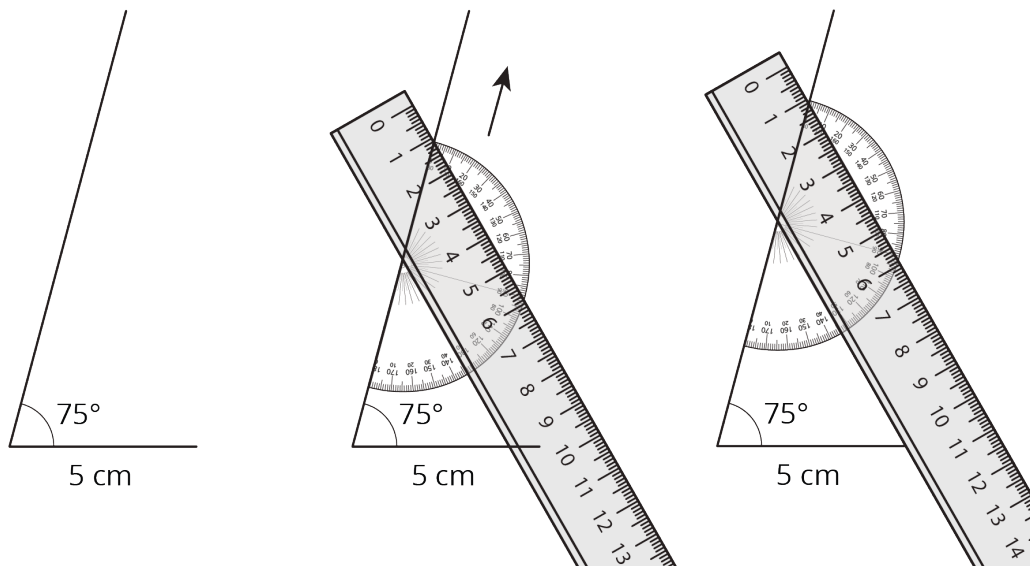

Access for English Language Learners

- | *MLR8 Discussion Supports.* Display sentence frames to help students explain whether any of the triangles they drew are identical copies to Jada's, Andre's or Lin's triangles. Examples: "I noticed _____ so I" "This triangle is/isn't identical because"
- | *Advances: Speaking, Conversing*

9.3 How Many Can You Draw?

 15 min

Activity Narrative

There is a digital version of this activity.

In this activity, students are asked to draw as many different triangles as they can with the given conditions. The purpose of this activity is to provide an opportunity for students to see the three main results for this unit: a situation in which only a unique triangle can be made, a situation in which it is impossible to create a triangle from the given conditions, and a situation in which multiple triangles can be created from the conditions. Students make use of the structure of triangle side lengths and angles as they explore these conditions (MP7).

Students are not expected to remember which conditions lead to which results, but should become more familiar with some methods for attempting to create different triangles. They will practice including various conditions into the triangles, including the conditions in different combinations, and practice recognizing when the resulting triangles are identical copies or not.

In the digital version of the activity, students use an applet to create triangles with given conditions. The applet allows students to change the conditions dynamically.

Standards

Addressing 7.G.A.2



Launch

Keep students in the same groups. Tell students they must try at least two different times to draw a triangle with the measurements given in each problem. Give students 5 minutes of quiet work time followed by time to discuss their different triangles with a partner. Follow with a whole-class discussion. Provide access to geometry toolkits.



Access for Students with Disabilities

Action and Expression: Internalize Executive Functions. To support organization, provide students with a printed graphic organizer to categorize the different triangles by condition.

Supports accessibility for: Language, Organization



Student Task Statement

1. Draw as many different triangles as you can with each of these sets of measurements:
 - a. Two angles measure 60° , and one side measures 4 cm.
 - b. Two angles measure 90° , and one side measures 4 cm.
 - c. One angle measures 60° , one angle measures 90° , and one side measures 4 cm.
2. Which of these sets of measurements determine one unique triangle? Explain or show your reasoning.

Student Response

1. Sample responses:
 - a. Two orientations of the same triangle.

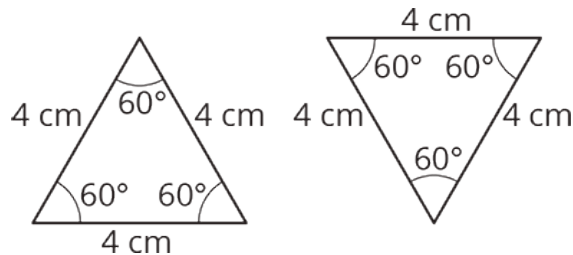

- b. Two attempts to draw a triangle with two 90° angles and a 4-cm side. There is no possible triangle with these conditions.

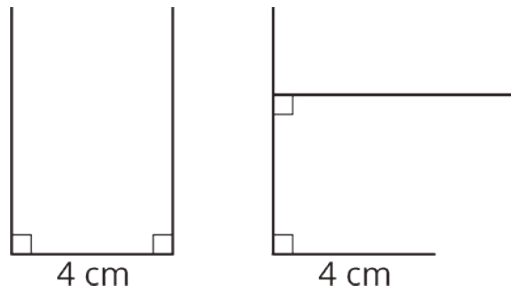

- c. Three different triangles can be made with the conditions.



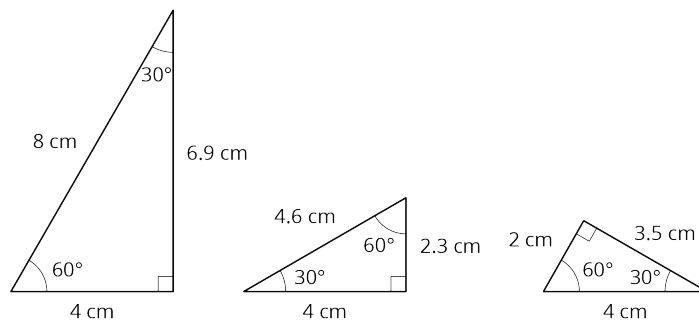

2. Only the first set of measurements determine a unique triangle.

Building on Student Thinking

Some students may draw two different orientations of the same triangle for the third set of conditions, with the 4-cm side in between the 60° and 90° angles. Prompt them to use tracing paper to check whether their two triangles are really different (not identical copies).

Some students may say the third set of measurements determines one unique triangle, because they assume the side length must go between the two given angle measures. Remind them of the discussion about Lin's triangle in the previous activity.

Are You Ready for More?

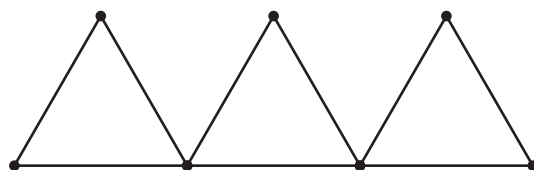

In the diagram, 9 toothpicks are used to make three equilateral triangles. Figure out a way to move only 3 of the toothpicks so that the diagram has exactly 5 equilateral triangles.

Extension Student Response

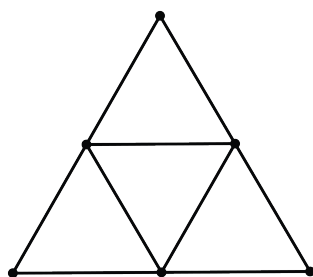

There are four small equilateral triangles and one large one.

Activity Synthesis

Ask students to indicate how many *different* triangles (triangles that are not identical copies) they could draw for each set of conditions. Select students to share their drawings and reasoning about the uniqueness of each problem. Discuss the methods that students used as they thought about other triangles that might fit the conditions.



Consider asking some of the following questions:

- “Which conditions produced a unique triangle?” (the first set of conditions)
- “Were there conditions that produced more than one triangle?” (the third set of conditions)
- “Were there conditions you could not draw a triangle for?” (the second set of conditions)
- “Why could you not draw a triangle for the second set of conditions?” (because two sides are parallel and will never intersect)

If not mentioned by students, explain to students that for the third set of conditions it is possible that all students drew identical copies using the 4-cm length as the side between the 60° and 90° angles. Consider asking them to think of the previous activity and to try to draw the triangle the way Lin would.

In grade 7, students do not need to know that the angle measures within triangle have a sum of 180° . Tell them that next year they will learn more about why these different conditions determine different numbers of triangles.

Lesson Synthesis

Here are some questions for discussion:

- Sometimes a set of conditions result in a unique triangle. What other results can come from a set of conditions? (It could be impossible, or they could be used to make multiple triangles.)
- If you are given a side length and two angles, what would you do to try to get started making different triangles? (Draw a line segment with the given length and put the two angles on each end. Then I would try leaving one angle on one end, but using Lin’s method of using a protractor and sliding it along for the other angle to create a triangle. Finally, I would do something similar, but switch which angle is next to the given length.)

9.4

Checking Diego’s Triangle

5 min

Cool-down

Standards

Addressing 7.G.A.2

Student Task Statement

When asked to draw a triangle with two 45° angles and a side length of 8 cm, Diego drew this triangle.

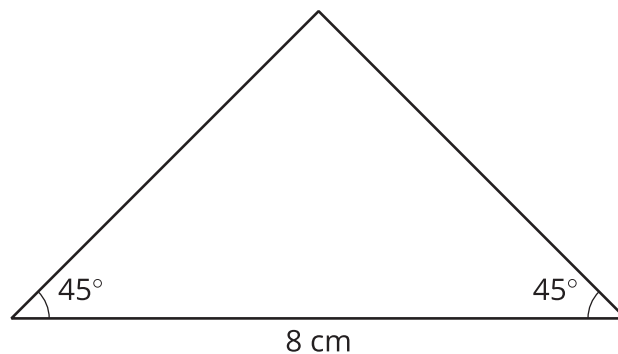

1. Does Diego's shape meet the requirements?
2. Is there a different triangle Diego could have drawn that would meet the requirements? Explain or show your reasoning.

Student Response

1. Yes. Sample reasoning: Diego's triangle has two 45° angles and a side length of 8 cm.
2. Yes, there is another possible triangle. Sample reasoning: Diego could keep one 45° angle next to the 8-cm side, but move the other one across from the 8-cm side.

Responding to Student Thinking

Points to Emphasize

If most students struggle with creating a shape that fits measurement requirements and with determining if it is unique, focus on these skills when doing this practice problem:

Grade 7, Unit 7, Lesson 9, Practice Problem 2

Lesson 9 Summary

Sometimes, we are given two different angle measures and a side length, and it is impossible to draw a triangle. For example, there is no triangle with side length 2 and angle measures 120° and 100° :

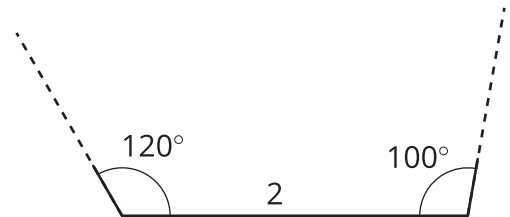

Sometimes, we are given two different angle measures and a side length between them, and we *can* draw a unique triangle. For example, if we draw a triangle with a side length of 4 between angles 90° and 60° , there is only one way in which they can meet up and make a triangle:

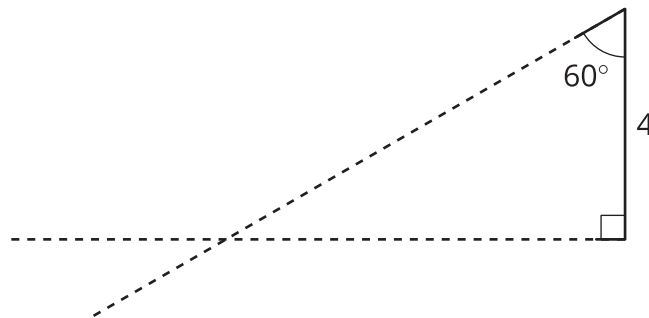

Any triangle drawn with these three conditions will be identical to the one above, with the same side lengths and the same angle measures.

Lesson 9 Practice Problems

1 Student Task Statement

Use a protractor to try to draw each triangle. Which of these three triangles is impossible to draw?

- A triangle where one angle measures 20° and another angle measures 45°
- A triangle where one angle measures 120° and another angle measures 50°
- A triangle where one angle measures 90° and another angle measures 100°

Solution

It is impossible to draw a triangle where one angle measures 90° and another angle measures 100° .

2 Student Task Statement

A triangle has an angle measuring 90° , an angle measuring 20° , and a side that is 6 units long. The 6-unit side is in between the 90° and 20° angles.

- Sketch this triangle and label your sketch with the given measures.
- How many unique triangles can you draw like this?

Solution

a.

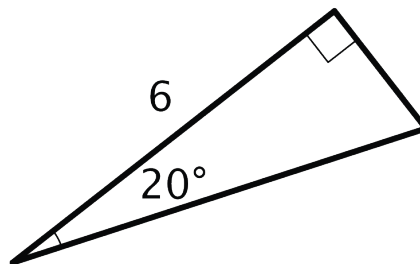

- b. There is only one triangle that fits this description, as long as the 6-unit side is between the two given angles.

3 from Unit 5, Lesson 13

Student Task Statement

- Find a value for x that makes $-x$ less than $2x$.
- Find a value for x that makes $-x$ greater than $2x$.

Solution

Answers vary. Sample response:

1. 1, because -1 is less than $2 \cdot 1$.
2. -3 , because 3 is greater than $2 \cdot -3$.

4

from Unit 5, Lesson 3



Student Task Statement

One of the particles in atoms is called an electron. It has a charge of -1 . Another particle in atoms is a proton. It has a charge of $+1$.

The overall charge of an atom is the sum of the charges of the electrons and the protons. Here is a list of common elements.

	charge from electrons	charge from protons	overall charge
carbon	-6	$+6$	0
aluminum	-10	$+13$	
phosphide	-18	$+15$	
iodide	-54	$+53$	
tin	-50	$+50$	

Find the overall charge for the rest of the atoms on the list.

Solution

Aluminum: $(-10) + (+13) = +3$

Phosphide: $(-18) + (+15) = -3$

Iodide: $(-54) + (+53) = -1$

Tin: $(-50) + (+50) = 0$

5

from Unit 4, Lesson 3



Student Task Statement

A factory produces 3 bottles of sparkling water for every 7 bottles of plain water. If those are the only two products they produce, what percentage of their production is sparkling water? What percentage is plain?



Solution

30% of the production is sparkling water. 70% of the production is plain water.

